

## Ihr sicherer Gewinn

### Formgebung, Bauart

Platzsparend dank kompakter Bauart, klare geometrische Form, keine vorstehenden Kanten.  
Einfacher Aufbau von Portalkombinationen dank frei wählbarer Länge des Grundprofils.  
Hundertprozentige Reproduzierbarkeit dank formschlüssigem Aufbau.

### Hubeinstellung, Überwachung

Flexibler Einsatz und hohe Wiederverwendbarkeit, da jeder beliebige Hub im Hubbereich einstellbar.  
Einfaches und schnelles Einrichten dank Hubjustierung unter Druck, kein Nachjustieren der Sensoren. Hohe Verfügbarkeit durch einfachen Austausch handelsüblicher Sensoren im Servicefall.

### Modular

Minimaler Konstruktions- und Montageaufwand dank durchdachtem System und einheitlichem Rastermass.

## Your definitive gain

### Style, Design

Space-saving, thanks to compact design, simple geometric form, no protruding edges.  
Simple assembly of portal combinations, thanks to freely selectable length of the base profile.  
One-hundred percent reproducibility, thanks to positive interlocking design.

### Travel Adjustment, Monitoring

Flexible usage and high reusability, since every optional stroke within the range of travel can be set.  
Simple and fast setup, thanks to travel adjustment under pressure, no readjustment of the sensors.  
High availability due to easy exchange of commercial sensors in the event of service.

### Modular

Minimal construction and assembly work required, thanks to well thought out system and uniform grid spacing.

# Linearachsen | Linear Axes

## Technische Daten – Zusammenfassung | Technical Data – Summary

			Pneumatische Achsen Pneumatic Axes				Elektrische Achsen Electrical Axes			
			LM 6 P	LM 8 P	LM 8 PV	LM 10 P	LM 6 PE	LM 8 PE	LM 8 PEV	LM 10 PE
Standard Hublängen h [mm]: Standard stroke lengths h [mm]: Gesamtlänge [mm]: Overall length [mm]:	L	0-150	408	468	468	558	483	543	543	543
		0-270	528	588	588	678	603	663	663	663
		0-390	648	708	708	798	723	783	783	783
		0-510	768	828	828	918	843	903	903	903
		0-630	888	948	948	1038	963	1023	1023	1023
		0-750	1008	1068	1068	1158	1083	1143	1143	1143
		0-990				1398	1323	1383	1383	1383
		0-1230				1638	1563	1623	1623	1623
Hublänge max. [mm]: Stroke length max. [mm]:			3720	3660	3660	3570	3720	3660	3585	3585
Gesamtlänge max. [mm]: Overall length max. [mm]:			3978	3978	3978	3978	4053	4053	4053	4053
Zylinderdurchmesser [mm]: Cylinder diameter [mm]:			18	25	25	25				
Zwischenpositionen [-]: Intermediate positions [-]:										
Theor. Kraft Fa/Fb [N]: (bei 5bar)		126/126								
Theor. force Fa/Fb [N]: (at 5 bar)		245/245								
Theor. zulässige Kraft Fa/Fb [N]: Theor. permissible force Fa/Fb [N]:							540	900	900	900
Maximale statische Momente [Nm]:		Ma	96	400	400	950	96	400	400	950
Maximum static orques [Nm]:		Mb	96	400	400	950	96	400	400	950
		Mc	64	192	560	480	64	192	560	480
Wiederholgenauigkeit [mm]: Repeat accuracy [mm]:			+/- 0,02	+/- 0,02	+/- 0,02	+/- 0,02	+/- 0,1	+/- 0,1	+/- 0,1	+/- 0,1
Max. zulässige Masse [kg]: Max. permissible mass [kg]:			4	8	16	16	4	8	16	16
Gewicht [kg]:   Torques [kg]:		0-150	4,1	7,6	9,8	11,0	4,1	8,2	10,2	12,5
		0-270	5,0	9,4	12,1	13,0	4,7	9,7	12,1	13,3
		0-390	5,9	11,2	14,3	15,0	5,4	11,2	14,1	15,0
		0-510	6,8	13,0	16,6	17,0	6,0	12,7	16,1	16,7
		0-630	7,7	14,8	18,8	19,0	6,6	14,2	18,1	18,4
		0-750	8,7	16,6	21,1	21,0	7,3	15,7	20,0	20,1
		0-990	9,8	18,2	23,7	25,0	8,5	18,7	24,0	23,6
		0-1230	11,4	19,8	25,3	29,0	9,8	21,7	28,0	27,0
Luftverbrauch pro Zyklus bei 5bar und Nennhub [NI]: Air consumption per cycle at 5 bar and nominal stroke [NI]:		0-150	0,45	0,80	0,80	0,80				
		0-270	0,78	1,45	1,45	1,45				
		0-390	1,12	2,10	2,10	2,10				
		0-510	1,46	2,75	2,75	2,75				
		0-630	1,79	3,40	3,40	3,40				
		0-750	2,13	4,05	4,05	4,05				
		0-990				5,35				
		0-1230				6,65				
Pneumatikanschlüsse: Pneumatic connections:			G1/8"	G1/8"	G1/8"	G1/8"				

# Linearachsen | Linear Axes

## Technische Daten – Belastungsdiagramme | Technical Data – Load Diagrams

### Längsbelastung | Axial Load

Die Grafik zeigt die Auslenkung  $f$  des Schlittens im Punkt A (Hebelarm 100 mm) unter Einwirkung des Momentes  $M_a$ .

The graph shows the deflection  $f$  of the slide at point A (lever arm 100 mm) under the effect of the torque  $M_a$ .

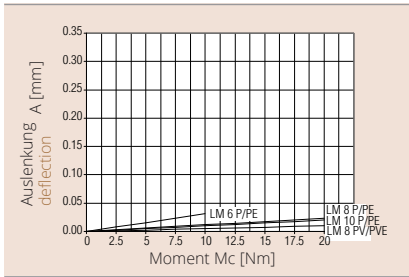
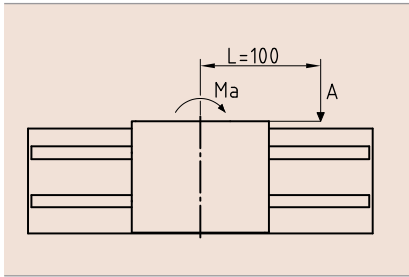

### Querbelastung | Transverse Load

Die Grafik zeigt die Auslenkung  $f$  des Schlittens im Punkt A (Hebelarm 100 mm) unter Einwirkung des Momentes  $M_b$ .

The graph shows the deflection  $f$  of the slide at point A (lever arm 100 mm) under the effect of the torque  $M_b$ .

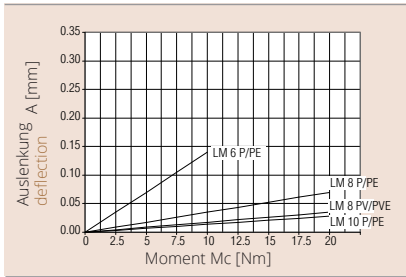
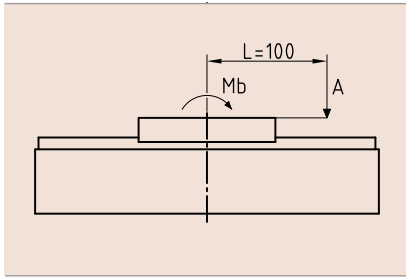

### Seitenbelastung | Lateral Load

Die Grafik zeigt die Auslenkung  $f$  des Schlittens im Punkt A (Hebelarm 100 mm) unter Einwirkung des Momentes  $M_c$ .

The graph shows the deflection  $f$  of the slide at point A (lever arm 100 mm) under the effect of the torque  $M_c$ .

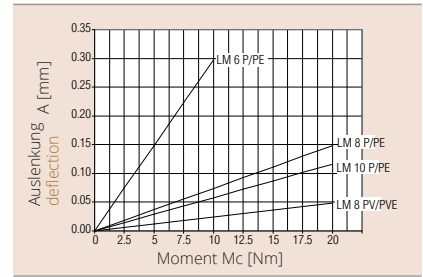
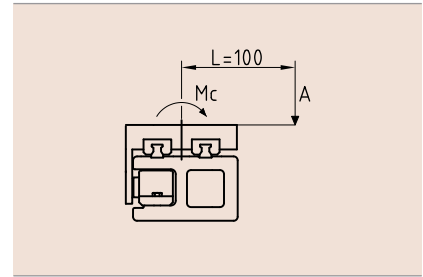

### Biegekennlinien | Bending characteristics

Das Diagramm zeigt die Durchbiegung des Aluminiumprofils, Lastfall statisch

The diagram shows the sagging of the aluminium profile, static loading

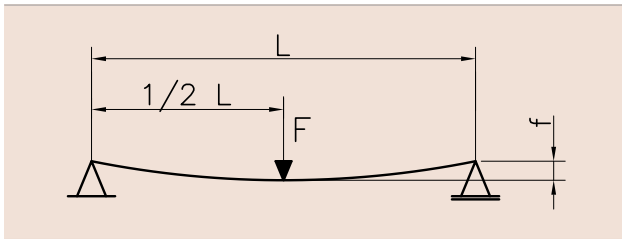

### Momente Achse Torques Axis

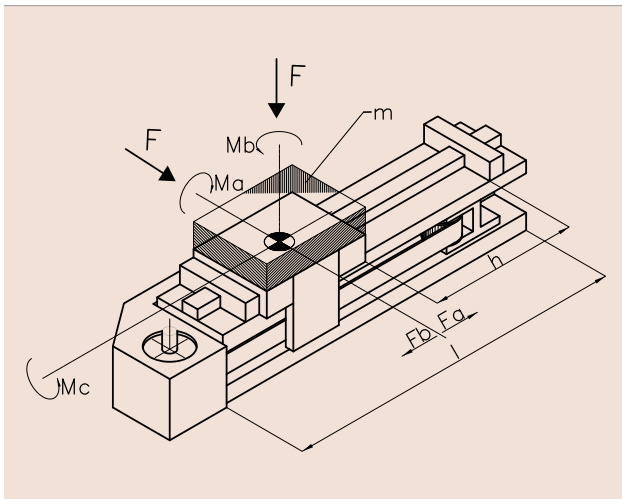

### LM 6 P / LM 6 PE

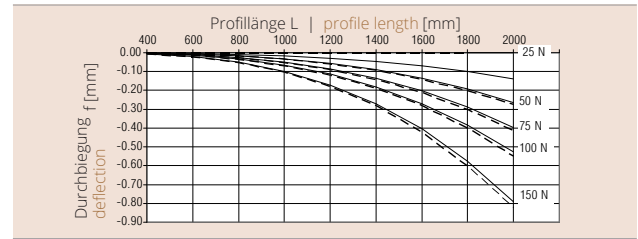

### LM 8 P / LM 8 PV / LM 8 PE / LM 8 PEV

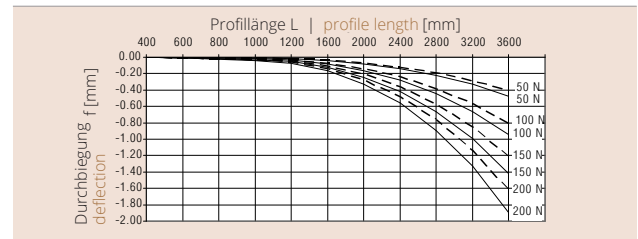

### LM 10 P / LM 10 PE

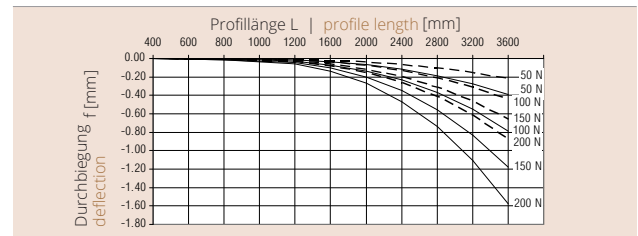

LM 6 PE

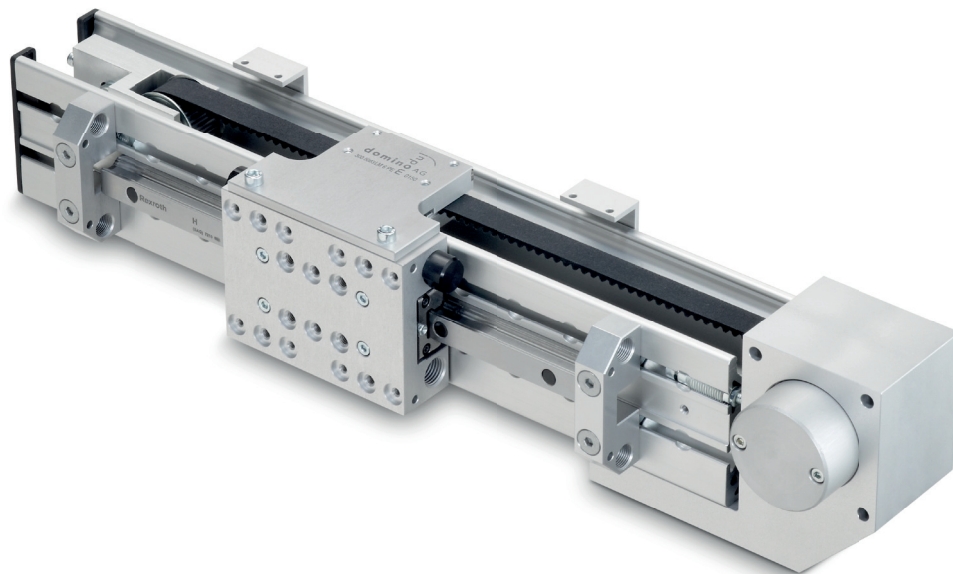

<b>Technische Daten, hubunabhängig</b>		<b>Technical data, stroke-independent</b>		
Antriebsraddurchmesser		Drive wheel diameter		33,42 mm
Zähnezahl Antriebsrad		Number of teeth, drive wheel		21
Zahnteilung		Tooth pitch		5 mm
Hub bei 1 Umdrehung des Antriebsrades		Stroke at 1 drive wheel rotation		105 mm
theor. Kraft bei 1 Nm Fa/Fb		Theor. force at 1 Nm Fa/Fb		60 N
theor. zulässige Kraft Fa/Fb		Theor. permissible force Fa/Fb		540 N
max. Geschwindigkeit		Max. speed		4 m/s
max. Beschleunigung/Verzögerung		Max. acceleration/deceleration		10 m/s <sup>2</sup>
Antriebsdrehmoment		Driving torque		0 bis 9 Nm
Translatorisch bewegte Grundmasse (Schlitten, Lager, Zahnriemen etc.)		Basic mass moved through linear motion (slide, bearing, toothed belt etc.)		0,9 kg
Antriebsrad:	Durchmesser x Breite Gewicht Material Stahl	Drive wheel:	diameter x width weight material Steel	Ø 33 mm x 22 mm 0,095 kg
Umlenkrad:	Durchmesser x Breite Gewicht inkl. Lager Material Aluminium	Guide wheel:	diameter x width weight incl. bearing material Aluminium	Ø 33 mm x 22 mm 0,035 kg
Reibmoment		Frictional torque		0,15 Nm
Temperaturbereich		Temperature range		0 – 60°C
Wiederholgenauigkeit		Repeat accuracy		+/-0.1 mm
max. zulässige Masse		Max. permissible mass		m 4 kg
max. statische Momente		Max. static torques		Ma 96 Nm Mb 96 Nm Mc 64 Nm
<b>Technische Daten, hubabhängig</b>		<b>Technical data, stroke-dependent</b>		
Siehe Seite 10		See page 10		

# Linearachsen | Linear Axes

LM 6 PE – elektrische Linearachse | LM 6 PE – Electrical Linear Axis

## Massbild LM 6 PE | Dimensional drawing LM 6 PE

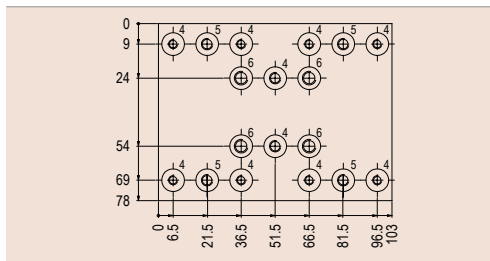
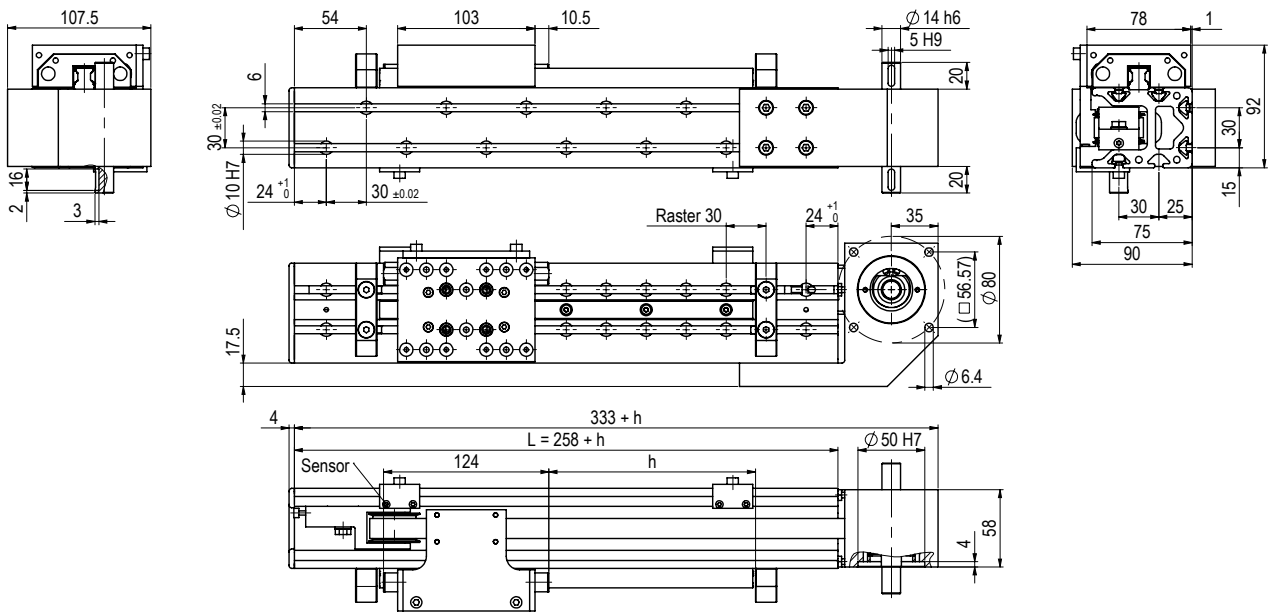

Nr. Zentrierung No. Centering	Gewinde Thread
4 $\varnothing 10H7 / 2.1$ tief   deep	M4
5 $\varnothing 10H7 / 2.1$ tief   deep	M5
6 $\varnothing 10H7 / 2.1$ tief   deep	M6

Lochdistanz +/-0.02 mm  
Hole distance +/-0.02 mm

Bezeichnung	Designation	Bestellnr.   Order no.
LM 6 PE-150 li	links   left	300 5065
LM 6 PE-270 li		300 5066
LM 6 PE-390 li		300 5067
LM 6 PE-510 li		300 0092
LM 6 PE-630 li		300 0093
LM 6 PE-750 li		300 5068
LM 6 PE-990 li		300 5063
LM 6 PE-1230 li	300 5064	
LM 6 PE-150 re	rechts   right	300 5083
LM 6 PE-270 re		300 5084
LM 6 PE-390 re		300 5085
LM 6 PE-510 re		300 5086
LM 6 PE-630 re		300 5087
LM 6 PE-750 re		300 5088
LM 6 PE-990 re		300 5089
LM 6 PE-1230 re	300 5090	
Sonderlänge bis 3720 mm	Custom length up to 3720 mm	
inkl. 4 Zentrierringe $\varnothing 10$ , 1 Abdeckkappe	Incl. 4 centering rings $\varnothing 10$ , 1 cover caps	

## Zubehör | Accessories

Zentrierring $\varnothing 10$	Centering ring $\varnothing 10$	300 1522
Endschalter 8 x 8	Limit switch 8 x 8	301 5214
Flansche, Kupplungen siehe Seite 28	Flange, shaft coupling, see page 28	
Energieführungsketten siehe Seite 29	Energy management chains, see page 29	